

OAKLAND CUSD #5

**3<sup>RD</sup> GRADE**  
**MAY 4 - 8, 2020**

DEDE CHILDRESS

## Week of May 4-8

### Mrs. Childress's 3rd Grade

Mrs. Childress's office hours:

Monday 8-10am

Tuesday 10-12

Wednesday 12-2pm

Thursday 2-4pm

You may email completed work to [dede.childress@oakland5.org](mailto:dede.childress@oakland5.org) (or drop off at school) every Monday.

Subject	Choice 1	Choice 2	Choice 3
<b>Math</b> (Choose 1 to turn in)	Do 2 rounds of Xtra Math. See instructions below.	Complete a Drops in the Bucket. (attached #32)	Complete the word problems that are attached.
<b>Reading</b> (Choose 1 to turn in)	Read a story of your choice and answer the 10 questions.	Read a story of your choice and write a 5 sentence summary.	Read a story of your choice and complete a book report. (2 pages)
<b>Writing</b> (Choose 1 to turn in)	Write a sentence for each word provided.	Write a paragraph (5 complete sentences) about your favorite thing about 3rd grade.	Make up your own story. Must be one page long.
<b>Free Choice Option #1</b> (Choose 1 to turn in)	Pick a Scholastic News to read and answer the questions on the back page. To read the digital copy: go to <a href="http://sn3.scholastic.com/">http://sn3.scholastic.com/</a> click Login (top right), Choose- "I am a student" and use the password: childress2020	Use your Social Studies textbook to write the definitions listed on the attached worksheet. (3 pages)	Use your Social Studies textbook to answer the attached review questions.
<b>Free Choice Option #2</b> (Choose 1 to turn in)	Use your Science textbook to write the definitions listed on the attached worksheet. (2 pages)	Use your Science textbook to answer the attached review questions.	Use your Science textbook to answer the following critical thinking questions.

\*Xtra Math: go to [xtramath.org](http://xtramath.org) - click "sign in" (top right)- for the email use:

[kelly.mcconaha@oakland5.org](mailto:kelly.mcconaha@oakland5.org)- type in your child's name and their Pin # (Mrs. McConaha will send me the report that shows who has completed for your grade)



Name : \_\_\_\_\_

Score : Mrs. Childers 3rd Grade

Teacher : \_\_\_\_\_

Date : May 4-8

Choice #3

### Word Problems

- 1 ) Fred has 70 cents in his bank.  
How many dimes does Fred have ?  
\_\_\_\_\_
- 2 ) Dan worked 35 hours in the last five days. Assuming that he worked the same amount of hours each day, how long did he work each day ?  
\_\_\_\_\_
- 3 ) Jason has 35 dollars in five dollar bills. How many five dollars bills does he have ?  
\_\_\_\_\_
- 4 ) There were a total of twenty-one basketball games during the three month season. If the games are equally divided, how many basketball games are played a month ?  
\_\_\_\_\_
- 5 ) A restaurant sold forty-nine hamburgers last week.  
How many hamburgers on average were sold each day ?  
\_\_\_\_\_
- 6 ) Melanie goes fishing with Sandy. They catch 14 trout.  
If they equally split up the trout, how many will each one get ?  
\_\_\_\_\_
- 7 ) Melanie was at the beach for five days and found twenty-eight seashells. She plans to give all of her seashells equally to her four friends.  
How many seashells will each friend get ?  
\_\_\_\_\_
- 8 ) Sam goes out to lunch with Benny and Tim. The total bill came to eighteen dollars. They decided to equally split up the bill, how much will each person have to pay ?  
\_\_\_\_\_
- 9 ) Mike has forty-two blue balloons. He wants to give his six friends the same number of blue balloons, how many will each friend get ?  
\_\_\_\_\_
- 10 ) Fred, Benny, and Tim have 21 rulers all together.  
If the rulers are equally divided, how many will each person get ?  
\_\_\_\_\_



Mrs. Childress

3rd Grade

Week: 5 May 4-8

Reading Choice #1

Directions: Read a book of your choice and answer the following questions *in cursive*.

Name: \_\_\_\_\_

Title of Book: \_\_\_\_\_

Author: \_\_\_\_\_

If it is a chapter book, tell me the pages you read: \_\_\_\_\_

**Please answer each question in complete sentences and in your best cursive handwriting.**

1. Could this story be true? Why or why not?
2. Where is the setting of the story?
3. Who is this story about?
4. What 3 words would you use to describe the main character?
5. Do you like the main character? Why or why not?
6. Does the main character have a problem? Why or why not?
7. How is the problem solved?
8. What is the scariest, saddest, most interesting, or most funny part of the story?
9. Do you like the story? Why or why not?
10. Would you recommend this book to a friend? Why or why not?

Mrs. Childress

3rd Grade

Week: 5 May 4-8

Reading Choice #2

Directions: Read a book of your choice and answer the following questions *in cursive*.

Name: \_\_\_\_\_

Title of Book: \_\_\_\_\_

Author: \_\_\_\_\_

If it is a chapter book, tell me the pages you read: \_\_\_\_\_

**Directions:** Write a summary of the story. Must be at least 5 sentences. Tell what happened in the beginning, middle, and end of the story.

---

---

---

---

---

---

---

---

---

---

Mrs. Childress

3rd Grade

Week: 5 May 4-8

Reading Choice #3

Directions: Read a book of your choice and answer the following questions. Answers should be written in complete sentences and in your best cursive handwriting.

Name: \_\_\_\_\_

Title of the Book: \_\_\_\_\_

Main Characters: \_\_\_\_\_

Setting of the Book: \_\_\_\_\_

What genre was the book you read? (fiction, nonfiction, historical fiction, fantasy, realistic fiction, fable, science fiction, mystery, biography) Circle one.

What happened in the beginning of the book? \_\_\_\_\_

\_\_\_\_\_

What happened in the middle of the book? \_\_\_\_\_

\_\_\_\_\_

**PAGE 2**

Mrs. Childress

3rd Grade

Week: 5 May 4-8

Reading Choice #3

**What happened at the end of the  
book?** \_\_\_\_\_

---

---

---

**What was your favorite part of the book and  
why?** \_\_\_\_\_

---

---

---



Mrs. Childress  
3rd Grade  
Week: 5 May 4-8  
Writing Choice #1

Name: \_\_\_\_\_

Directions: Write a (good 3rd grade) sentence using the word provided. Please use cursive and don't forget capital letters and end marks.

1. disagreed \_\_\_\_\_  
\_\_\_\_\_

2. prepaid \_\_\_\_\_  
\_\_\_\_\_

3. previous \_\_\_\_\_  
\_\_\_\_\_

4. resell \_\_\_\_\_  
\_\_\_\_\_

5. unlucky \_\_\_\_\_  
\_\_\_\_\_

Mrs. Childress

3rd Grade

Week: 5 May 4-8

Writing Choice #2

Name: \_\_\_\_\_

Directions: Write a paragraph telling about your favorite thing (or things) about 3rd grade. Must be at least 5 sentences and written in your best cursive handwriting.

---

---

---

---

---

---

---

---

---

---



Mrs. Childress

3rd Grade

Week: 5 May 4-8

Free Choice Option #1- Choice #2

Name: \_\_\_\_\_

Using your social studies book, find the vocabulary words listed below and write out (or type) the definition of each word. Vocabulary words will be in Chapter 3- Pages 62-81.

Rural area: \_\_\_\_\_

\_\_\_\_\_

hatchery: \_\_\_\_\_

\_\_\_\_\_

Pie graph: \_\_\_\_\_

\_\_\_\_\_

technology: \_\_\_\_\_

\_\_\_\_\_

profit: \_\_\_\_\_

\_\_\_\_\_

irrigate: \_\_\_\_\_

\_\_\_\_\_

**PAGE 2**

Mrs. Childress

3rd Grade

Week: 5 May 4-8

Free Choice Option #1- Choice #2

Name: \_\_\_\_\_

Dairy cow: \_\_\_\_\_

\_\_\_\_\_

pasture: \_\_\_\_\_

\_\_\_\_\_

Bar graph: \_\_\_\_\_

\_\_\_\_\_

ranch: \_\_\_\_\_

\_\_\_\_\_

plateau: \_\_\_\_\_

\_\_\_\_\_

coast: \_\_\_\_\_

\_\_\_\_\_

**PAGE 3**

Mrs. Childress

3rd Grade

Week: 5 May 4-8

Free Choice Option #1- Choice #2

**trawl:** \_\_\_\_\_

\_\_\_\_\_

**Seine:** \_\_\_\_\_

\_\_\_\_\_

Mrs. Childress

3rd Grade

Week: 5 May 4-8

Free Choice Option #1- Choice #3

Name: \_\_\_\_\_

Directions: answer the following questions using your Social Studies textbook. Answers will be in chapter 3 pages 62-81.

1. How have American farms changed over the years?
2. Where is the largest farming area west of the Rocky Mountains?
3. What are four kinds of dairy products?
4. Why are most ranches in the United States located in the West?
5. What two countries have fish as their main source of food?
6. Why are towns important to people in rural areas?
7. Why might some fruits and vegetables need to be picked as soon as they are ripe?
8. Why does milk travel to the dairy in a refrigerated truck?
9. Why might a rancher want to remove a sick sheep from the rest of the herd?
10. Some countries are trying to limit ocean fishing. What might happen if too many fish are caught?

Mrs. Childress

3rd Grade

Week: 5 May 4-8

Free Choice Option #2- Choice #1

Name: \_\_\_\_\_

**Directions:** Use your science textbook to write down the definition of each word. These will be found in Chapter 3 pages 65-89.

**environment:** \_\_\_\_\_

\_\_\_\_\_

**ecosystem:** \_\_\_\_\_

\_\_\_\_\_

**community:** \_\_\_\_\_

\_\_\_\_\_

**population:** \_\_\_\_\_

\_\_\_\_\_

**grassland:** \_\_\_\_\_

\_\_\_\_\_



**PAGE 2**

Mrs. Childress

3rd Grade

Week: 5 May 4-8

Free Choice Option #2- Choice #1

Name: \_\_\_\_\_

desert: \_\_\_\_\_

\_\_\_\_\_

tundra: \_\_\_\_\_

\_\_\_\_\_

wetland: \_\_\_\_\_

\_\_\_\_\_

Mrs. Childress

3rd Grade

Week: 5 May 4-8

Free Choice Option #2- Choice #2

Name: \_\_\_\_\_

**Directions:** Answer the following questions using your science textbook. Use chapter 3 pages 65-89.

1. Low land that is often covered by water is a(n) \_\_\_\_\_.
2. All the moose that live in one place are a(n) \_\_\_\_\_.
3. Everything that surrounds a living thing is its \_\_\_\_\_.
4. An ecosystem with hot days and little rain is a(n) \_\_\_\_\_.
5. All the populations living in the same place form a(n) \_\_\_\_\_.
6. The ecosystem that is coldest and farthest north is the \_\_\_\_\_.
7. All the living and nonliving things that interact in an area form a(n) \_\_\_\_\_.
8. An ecosystem with many grasses and few trees is a(n) \_\_\_\_\_.
9. Explain how dry soil and frozen soil affect the types of plants that grow in them.  
Give examples.
10. Explain how some desert plants are able to have enough water.

Mrs. Childress

3rd Grade

Week: 5 May 4-8

Free Choice Option #2- Choice #3

Name: \_\_\_\_\_

**Directions:** Answer the following questions using your science textbook. Use chapter 3 pages 65-89.

1. Explain how chapparal, coyotes, and ground squirrels depend on each other.
2. Wheat and oats are cereal grasses. Infer in which ecosystem these farm crops would grow best.
3. Desert snakes eat kangaroo rats. Predict what would happen to the population of rats if the population of snakes grew larger.
4. Which ecosystem has a warm, rainy climate?
5. Write a paragraph (5 sentences) about a plant or animal and how it survives in a desert ecosystem.

**Week of May 4-15, 2020**  
**3rd Grade Art**  
**Mrs. Sweeney**

Please pick 1 out of the 3 activities to complete every other week. Please email me a picture of your child completing the activities or submit the activity to the homework box located in the Lake Crest foyer. Some of the art projects require supplies. Please feel free to improvise if you do not have the required supplies, or reach out to me or the office and we will work together to get you what we need. Some basic supplies will be available for pick-up in the Lake Crest foyer.

Please email me at [jill.sweeney@oakland5.org](mailto:jill.sweeney@oakland5.org) or call the school and leave a message, and I will give you a call as soon as I can. My office hours are 8-10 am on Mondays and Wednesday and Tuesdays 10-12. I will be readily available at those times.  
School office hours: Monday-Thursday 7:30-11:30 and the phone is 217-346-2166.

If email submission is not an option, contact Mrs. Sweeney for alternative ways to submit work. Sketchbooks and Still Life Drawings can be placed in the Homework Turn-in box in the Lake Crest Foyer.

<b>Class</b>	<b>Choice 1</b>	<b>Choice 2</b>	<b>Choice 3 (Enrichment)</b>
3rd Grade	Toucan	Jaguar	Petunia

## Draw a Toucan

3<sup>rd</sup> grade / Choice / Sweeney  
May 4-15

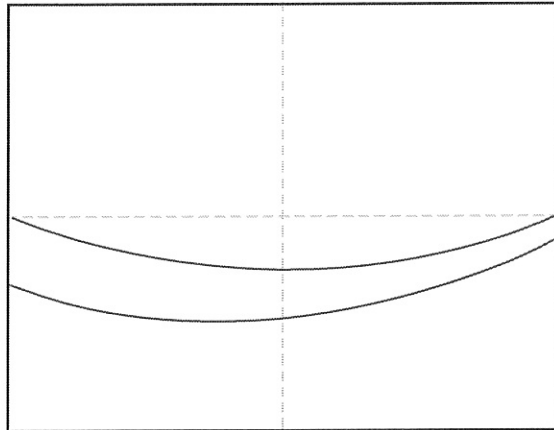

1. Draw a curvy branch.

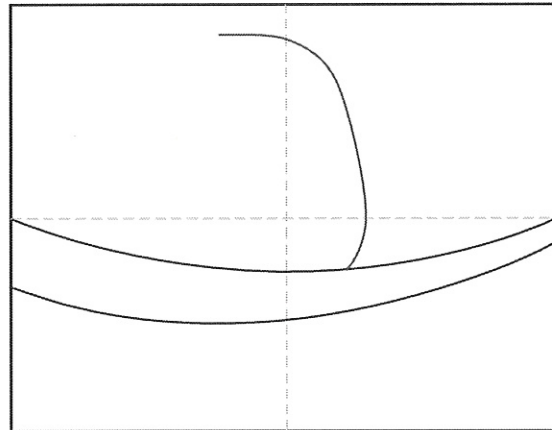

2. Draw one side of the body.

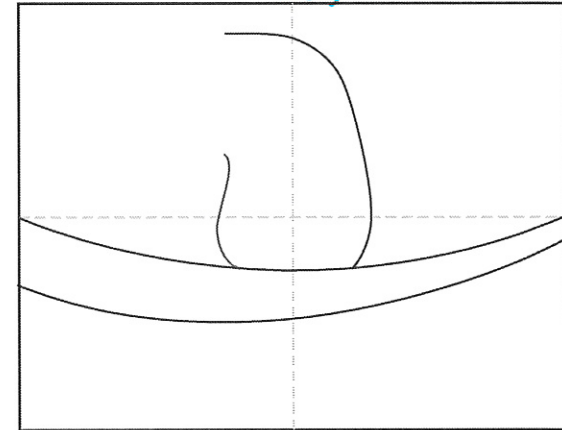

3. Draw the other side, with opening for beak.

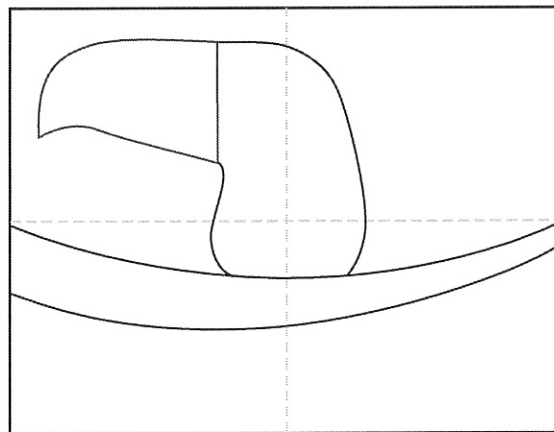

4. Attach a large beak.

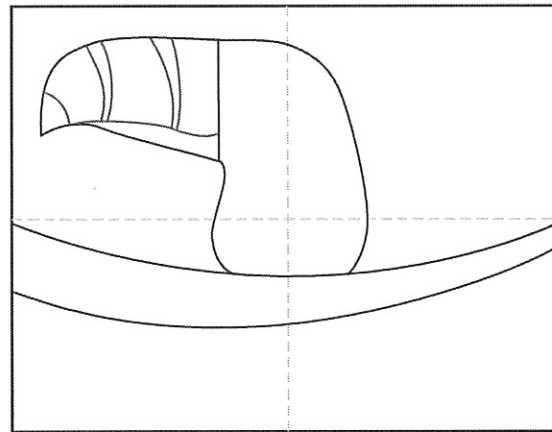

5. Add the beak details shown.

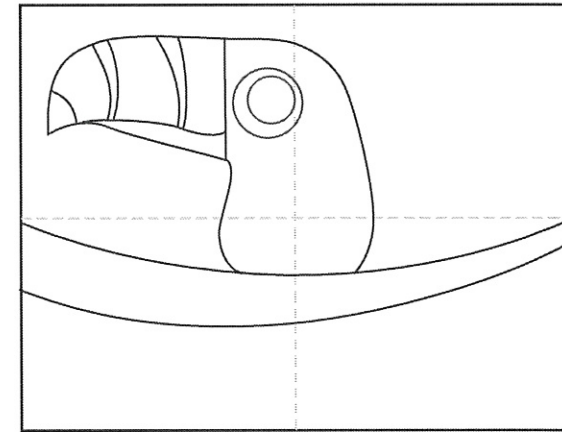

6. Draw two circles for the eye.

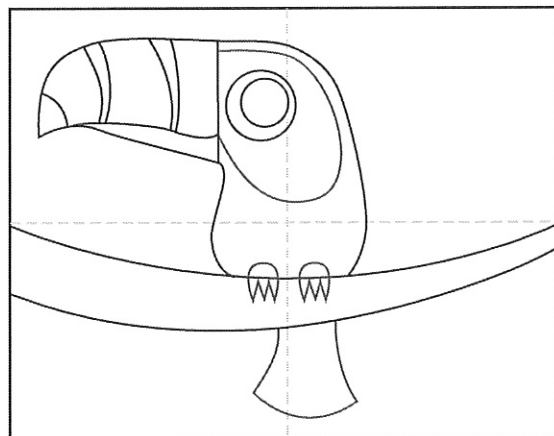

7. Add line around the eye, claws and tail.

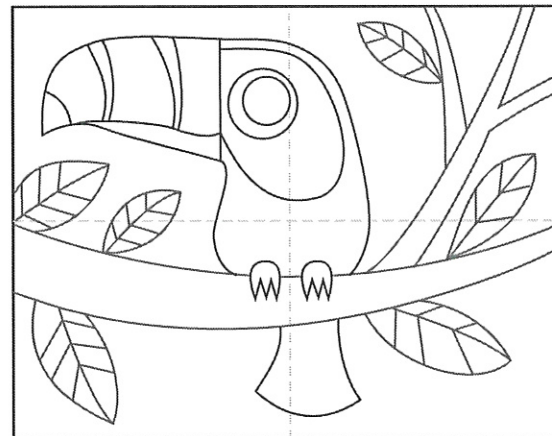

8. Fill the background with branches, leaves.



9. Trace with a marker and color.

# Petunia

3<sup>rd</sup> grade/choice 3/Sweeney

Watch the book Petunia on youtube: <https://www.youtube.com/watch?v=krV2p6FJyYc>



## Materials:

12" x 18" white paper or what you have available

Pencil and Eraser

Red, yellow, white, blue, green and black liquid tempera paint (or crayons)

Paint brush if painting

Black marker, black crayon or lack oil pastel as optional outing supplies.

## Directions:

### 1. Draw Petunia

#### How to Draw a Goose in 8 Easy Steps

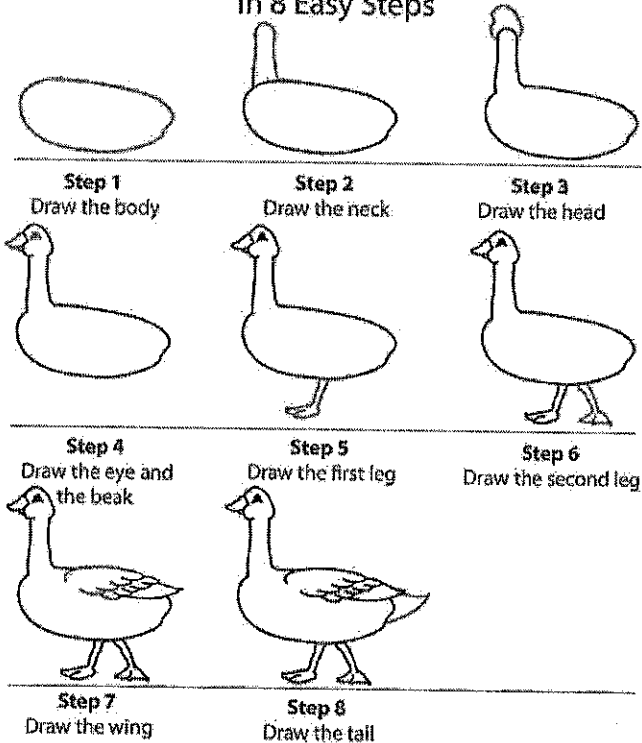

2. Draw flowers around Petunia.
3. Paint/color the background red.
4. Let dry and paint flowers.
5. Let dry and with a black crayon outline Petunia and flowers.

# Weeks of *May 4-15,* 2020 April Lee

Hello! This will be our final packet for Music this school year. It is with mixed emotions that I send it out to you. I feel sad we didn't get to have our Spring Concert, but I feel glad that Spring is in the air and Summer is just around the corner. Here's wishing you and your families all the best this season and the next!!!

Please don't forget about the Facebook group called Lake Crest Music. I believe I have invited everyone K-5. Each day or so I try to find some activity we can do together. Send me an email or make a comment if you liked a particular activity.

To complete Options #1 & #2 students will need a pencil. For Option #3, crayones will be needed. This work is due May 15.

My "office hours" are from 10:00 a.m. to noon on Mondays, Wednesdays, & Thursdays, but you can email me anytime with questions or concerns at [april.lee@oakland5.org](mailto:april.lee@oakland5.org).

<b>Class</b>	<b>Choice 1</b>	<b>Choice 2</b>	<b>Choice 3 (Enrichment)</b>
3rd Grade Music	Play a Tune word search	John Philip Sousa	Color by Note



# Play a Tune

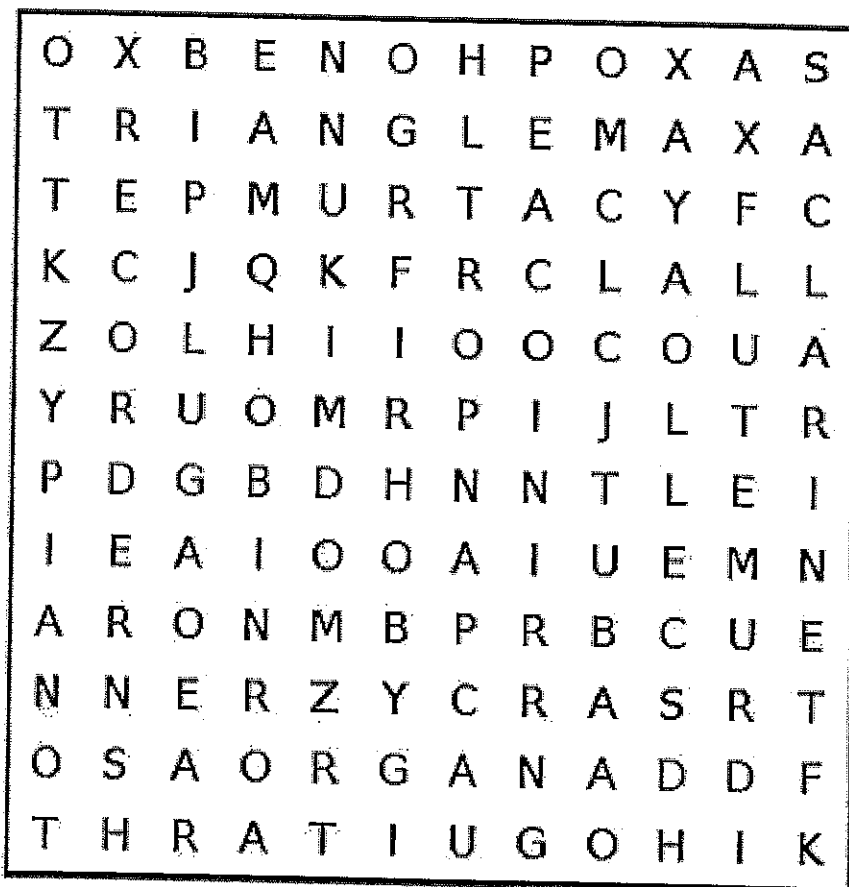
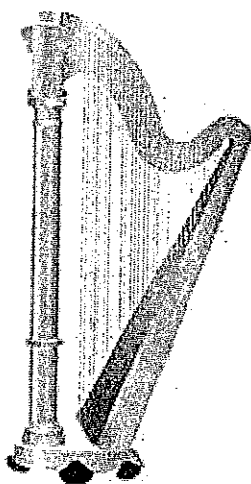

ACCORDION  
 BANJO  
 CELLO  
 CLARINET  
 DRUM  
 FLUTE  
 GUITAR

HARMONICA  
 HARP  
 MARIMBA  
 ORGAN  
 PIANO  
 RECORDER  
 SAXOPHONE

TRIANGLE  
 TRUMPET  
 TUBA  
 XYLOPHONE

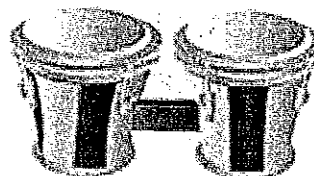



Mrs. Lee

Music

3rd grade

Option #2 p.1

May 4-15

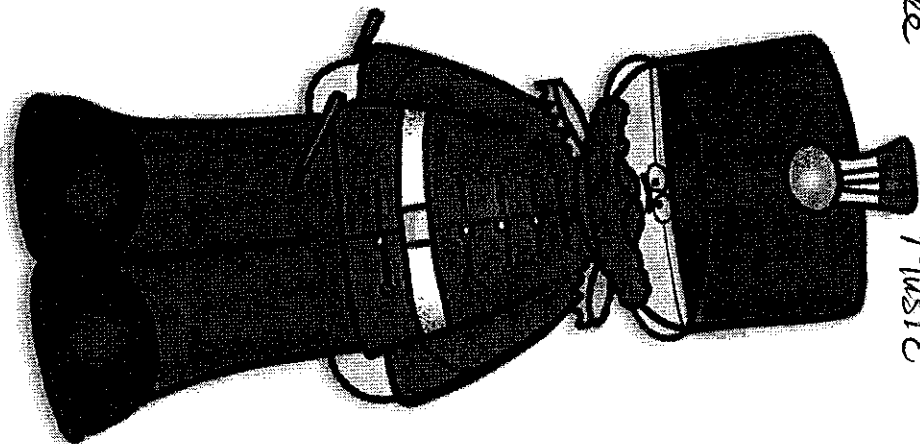

Mrs. Lee

Music

3rd grade

Option #2 p.1

May 4-15

### Famous Works

Stars and Stripes Forever

\*National March of the United States

Semper Fidelis

\*Official March of the Marine Corps

Washington Post March

# John Phillip Sousa

1854-1932

Romantic-Modern Period

"The March King," John Phillip Sousa, was born in Washington D.C. His father played trombone in the United States Marine Band. Sousa always loved bands and when he was 13, he almost ran off to join a circus band. His father found out about his plan and enlisted him in the Marine Corps instead.

Sousa studied and played many instruments including the flute, cornet, baritone, trombone, French horn, and violin. He met his wife playing the violin for a theater production.

Eventually, Sousa returned to the band world. He spent 12 years conducting the Marine Band and then started his own band that toured the world. Sousa also directed the President's Own Band under 5 presidents and served in World War I. He received the World War I Victory Medal.

Sousa died suddenly after conducting a band rehearsal where they had just played "The Stars and Stripes Forever"

Mrs. Lee

Music

3rd grade

Option #2 p. 2

May 4-15

Name:

Class:

May 4-15

# John Phillip Sousa

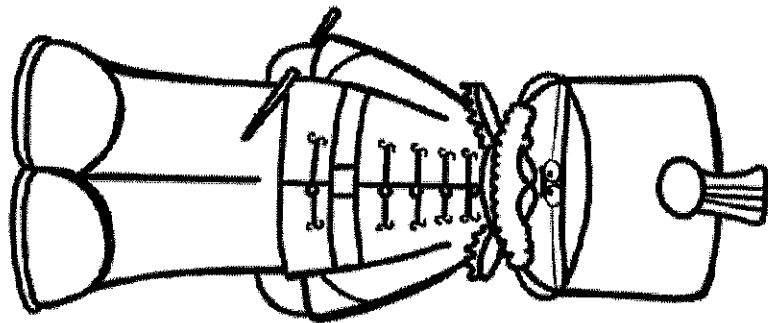

## Famous Works

\_\_\_\_\_

\_\_\_\_\_

\_\_\_\_\_

(Dates)

(Period of Music)

1. Famous

composer

2. Sousa was known as the

King.

3. He played many instruments including the

cornet, baritone, French horn, and

4. Sousa conducted the

Band for 12

years before starting his own band that toured the world.

5. Sousa also conducted the

Own Band under 5 Presidents.

6. Sousa served in

\_\_\_\_\_ and

received the Victory Medal for his service.

Mrs. Lee

Music

3rd grade

Option #2 p. 2



# Color By Note

Quarter Notes = Light Blue

Half Notes = Yellow

Quarter Rests = Brown

Half Rests = Dark Blue

Eighth Notes = Red

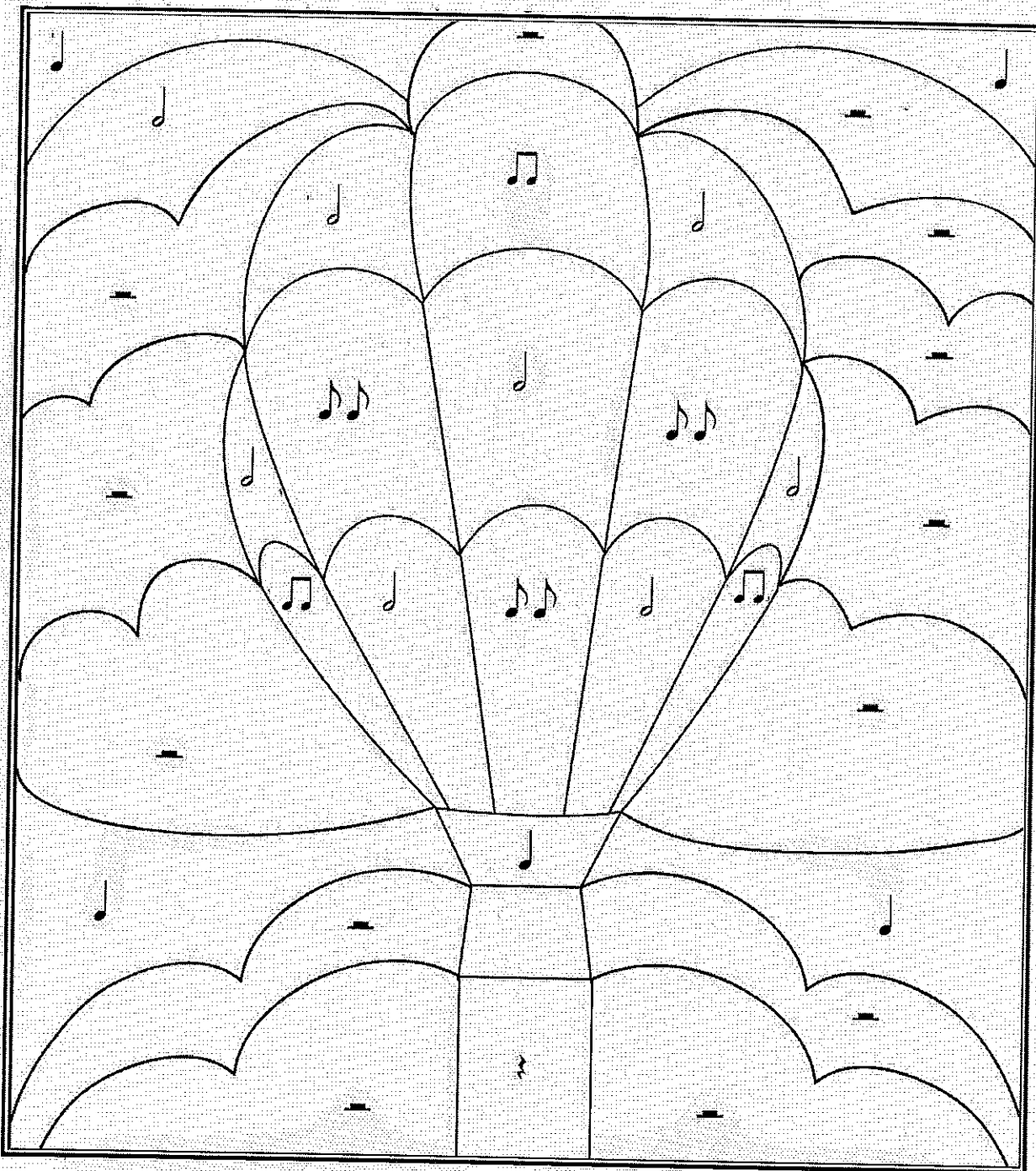

**Week of May 4 - May 8, 2020**  
**2nd/3rd PE**  
**Coach Kappy**

Please pick 3 out of the 5 activities to do for the week. Please email me a picture of your child completing the activities and the dates or email me a description of the activities. You or your child may also write a few sentences about the activity and submit to the homework box located in the Lake Crest foyer.

Please email me at [jenny.kapraun-veach@oakland5.org](mailto:jenny.kapraun-veach@oakland5.org) or call the school and leave a message, and I will give you a call as soon as I can.

<b>Class</b>	<b>Choice 1</b>	<b>Choice 2</b>	<b>Choice 3</b>	<b>Choice 4</b>	<b>Choice 5</b>
2nd/ 3rd Grade	Ride your bike for 15-20 minutes	Do an exercise Video/have a Dance Marathon	Go on a walk with your family or with a parent for 15-20 minutes	Play Basketball for 15-20 minutes.	Another physical activity that you do for 15 minutes or more (yard work, etc.)